

REMOTE ETC

REMOTE ELECTRONIC THROTTLE CONTROL



AT A GLANCE

- > A COMPACT, LIGHTWEIGHT ELECTRONIC THROTTLE CONTROL WHICH CAN BE MOUNTED REMOTELY ON THE VEHICLE
- > OPERATED BY CABLE OR LINKAGE
- > CAN BE CONFIGURED FOR ANALOGUE, PWM OR CANBUS SENSOR OUTPUTS
- > NON-CONTACT, HALL EFFECT SENSOR PROVIDES POSITION SENSING WITH ACCURACY AND RELIABILITY

PRODUCT DESCRIPTION

The Remote ETC has been created for use as a 'standalone' electronic throttle control for compact applications where there is no space to locate an ETC device, such as a foot pedal, in the normal position.

The ETC can be mounted in a remote location, where there is package space, and operated with a cable or linkage connected to a simple operating device.

It features the vSENSE™ non-contact sensor with patent-pending technology, configurable for a wide range of sensor output types.

The Kongsberg Automotive vSENSE™ non-contact, programmable Hall effect sensor seals out contaminants to provide enhanced reliability in all environments. With no moving parts to wear over time, the vSENSE™ sensor sets a new standard for accuracy and durability.



REMOTE ETC

REMOTE ELECTRONIC THROTTLE CONTROL



PRODUCT SPECIFICATIONS

PARAMETERS	SPECIFICATIONS
OPERATING TEMPERATURE	-40°C TO +85°C
IP RATING	IP67

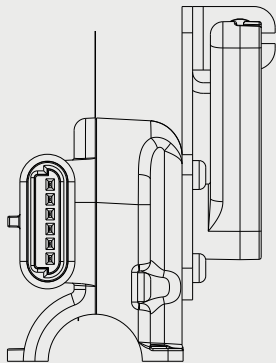
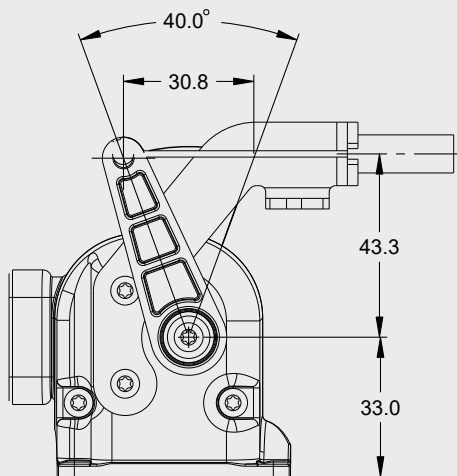
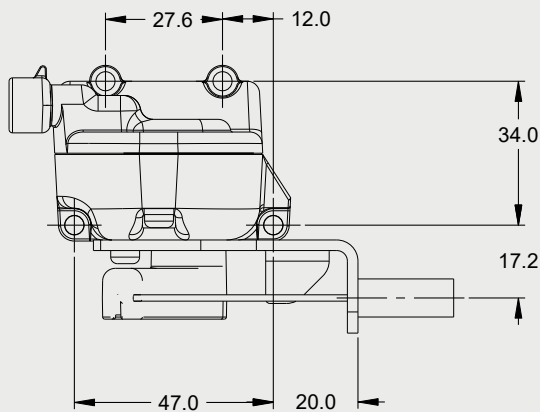

FEATURES

- > 40° OF ROTATION (OR 31MM OF CABLE TRAVEL)
- > EASILY MOUNTED
- > INTEGRATED SENSOR WITH METRIPACK 150 CONNECTOR

OPTIONS

- > CAN BE OPERATED WITH A LINKAGE OR CABLE
- > CAN BE SUPPLIED WITH OPERATING CABLE
- > SENSOR OUTPUT CAN BE CONFIGURED FOR A MULTITUDE OF APPLICATIONS