

MAC

MULTI AXIS ELECTRONIC HAND CONTROL



AT A GLANCE

- > A COMPACT, LIGHTWEIGHT HAND CONTROL, SUITABLE FOR ANY TYPE OF OFF HIGHWAY VEHICLE APPLICATION REQUIRING A MULTI AXIS, ELECTRONIC HAND CONTROL
- > CAN BE CONFIGURED TO DIFFERENT MECHANICAL CHARACTERISTICS AND SENSOR OUTPUTS
- > PERFORMANCE SPECIFICATION BASED ON KONGSBERG AUTOMOTIVE'S LONG STANDING EXPERIENCE AND KNOWLEDGE OF SHIFTERS AND HAND CONTROLS
- > NON-CONTACT, HALL EFFECT SENSOR PROVIDES POSITION SENSING WITH ACCURACY AND RELIABILITY

PRODUCT DESCRIPTION

Kongsberg Automotive is one of the world's leading manufacturers of manual and electronic gear shifters, with our systems fitted to over six million vehicles each year across Europe, North America, South America and Asia. Kongsberg Automotive has been designing and developing transmission shift controls for commercial vehicles for more than 40 years. Today we supply products to the world's leading manufacturers of trucks, buses and off-highway vehicles.

We have used this electronic shifter experience in creating this Multi Axis Electronic Hand Control for the Off Highway vehicle market. This control can be easily configured for a wide range of applications where precision, hand control is required.





PRODUCT SPECIFICATIONS

PARAMETERS	SPECIFICATIONS
RATED LIFE	> 500,000 CYCLES
OPERATING TEMPERATURE	-40°C TO +85°C
OPERATING VOLTAGE	8V TO 48V

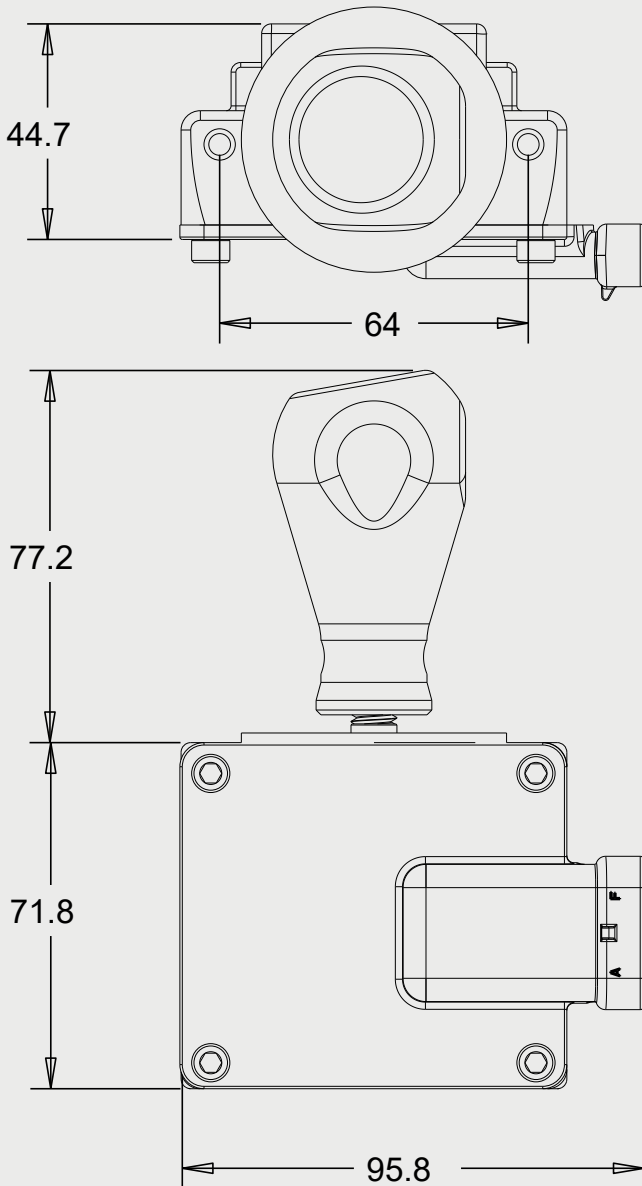

FEATURES

- > UP TO A MAXIMUM OF 15 DISCRETE POSITIONS (3 ROWS OF 5 POSITIONS EACH)
- > CANBUS SAEJ1939 DISCRETE OUTPUTS
- > INTEGRATED SENSOR WITH METRIPACK 150 CONNECTOR

OPTIONS

- > INDEX TRACKS WITH CUSTOM POSITIONS AND USER FORCES CAN BE GENERATED
- > POSITIONS CAN BE MOMENTARY OR STATIC
- > CUSTOM OR CUSTOMER INSTALLED GRIPS/ KNOBS CAN BE ACCOMMODATED