

KAntrak™ 1700 DISPLAY



AT A GLANCE

- > 2.3" GRAPHICAL HIGH RESOLUTION DOT MATRIX LCD DISPLAY
- > RUGGED ABS CASE
- > IP67 PROTECTION RATING
- > ADJUSTABLE BACKLIGHTING
- > 3 BUTTONS PROVIDE EASY NAVIGATION THROUGH SOFTWARE SCREENS
- > LED WARNING LIGHT TO NOTIFY OPERATOR OF VEHICLE/ENGINE FAULT
- > ALARM OUTPUT AND FUEL SENSOR INPUT STANDARD
- > BASIC ICON, BAR-GRAPHS AND ALPHANUMERIC DISPLAY
- > CE APPROVED DESIGN
- > NOW AVAILABLE WITH TIER 4 COMPLIANT MESSAGING WITHIN GEM (GENERIC ENGINE MONITORING) SOFTWARE

PRODUCT DESCRIPTION

KAntrak™ displays have established a new standard for intelligent, multi-function displays and are the perfect platform to empower your electronic systems with flexibility and control. The new KAntrak™ 1700 perfectly complements the existing KAntrak™ product range and is designed to provide market leading functionality in a compact display.

As off-road emissions regulations become ever more stringent, lower powered engines are requiring electronically controlled fueling to comply with the legislation. The ECU (Engine Control Unit) which controls the fueling and other engine functions receives and processes data on many aspects of the engine. This requires a Human Machine Interface (HMI) to provide the necessary data to the user to ensure safe and reliable operation.

The KAntrak™ 1700 display allows the user to easily monitor critical engine parameters such as oil pressure and water temperature as well as providing an alarm

system to alert the user when the ECU detects an engine fault. Its compact size is ideally suited for use on low power vehicles and equipment such as small construction machines, generators and agricultural equipment.

With its J1939 data bus, the KAntrak™ offers easy integration into most third party CAN-based systems. It can also be combined with many other Kongsberg Automotive electronic products, such as the MCM, DCSM, SKIM, and keypads, to create a full scale monitoring and control system for virtually any type of vehicle or industrial equipment.



PRODUCT SPECIFICATIONS

HARDWARE

Micro Controller	ARM Cortex M3 STM32F103RC
FLASH Memory	256Kb
RAM	47Kb

ELECTRICAL

Display	Dot Matrix LCD
Resolution	128 x 64 pixels
Power Requirements	9 to 32 VDC supply (reverse polarity protected)
Power Consumption	100mA (backlight off) 500mA (backlight on) @12VDC
Wiring Protection	Reverse polarity protected (fuse must be included)
Connector	Integrated Deutsch 6 way connector
Communications	Full CAN 2.0B

ENVIRONMENTAL

Operating temperature	-30°C to + 70°C
Storage Temperature	-40°C to + 80°C
Degree of Protection	IP67
Salt Spray	IEC 60068-2-52:1996
EMC	IEC 61000 and EN55022

MECHANICAL

Case material	ABS
Dimensions	76mm x 76mm (3.00" x 3.00")

SOFTWARE

The KAntrak 1700 is supplied with pre-installed GEM (Generic Engine Monitoring) software which allows the user to connect the display directly to a J1939 CANbus and monitor many different engine and vehicle parameters. A series of easy to use menu screens allow the display to be configured to suit the individual application. Options include language and unit selection and various screen layouts to show parameter icons, bar-graphs and alphanumeric text.

For high volume applications a SDK (Software Development Kit) will be available, enabling fully customized software to be created to suit specific product requirements.

- > Excellent sunlight readability
- > Integral Deutsch DT04-6P style connector
- > Mating connector Deutsch DT06-6S

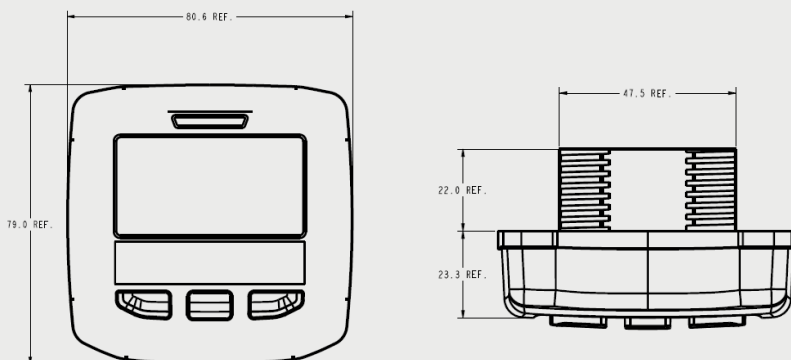

FEATURES

- > EXCELLENT SUNLIGHT READABILITY
- > INTEGRAL DEUTSCH DT04-6P STYLE CONNECTOR
- > MATING CONNECTOR DEUTSCH DT06-6S
- > CONNECTOR PIN IDENTIFICATION:



1. POWER -VE
2. POWER +VE
3. CAN HI
4. CAN LO
5. BUZZER ALARM OUTPUT
6. FUEL SENSOR INPUT

OPTIONS

- > SHIFT LEVER MOVEMENT:
 - » DETENT PLATE, STANDARD OR CUSTOMIZED, WITH UP TO 14 POSITIONS
 - » REVERSE SPRING TO RETURN LEVER TO NEUTRAL-POSITION
 - » FRICTION PAD
- > SIDE MOVEMENT OF LEVER POSSIBLE TO FOLLOW A Z-GATE SHIFT PATTERN
- > OPTIONS AVAILABLE FOR POSITIONAL ILLUMINATION
- > OPTION AVAILABLE FOR ADDITIONAL EXTERNAL SWITCHES
- > INSTALLATION OPTIONS:
 - » STANDARD MOUNTING BRACKET
 - » NO BRACKET
 - » CUSTOMIZED BRACKET