

CTT300

COMPACT TILT AND TELESCOPE STEERING COLUMN

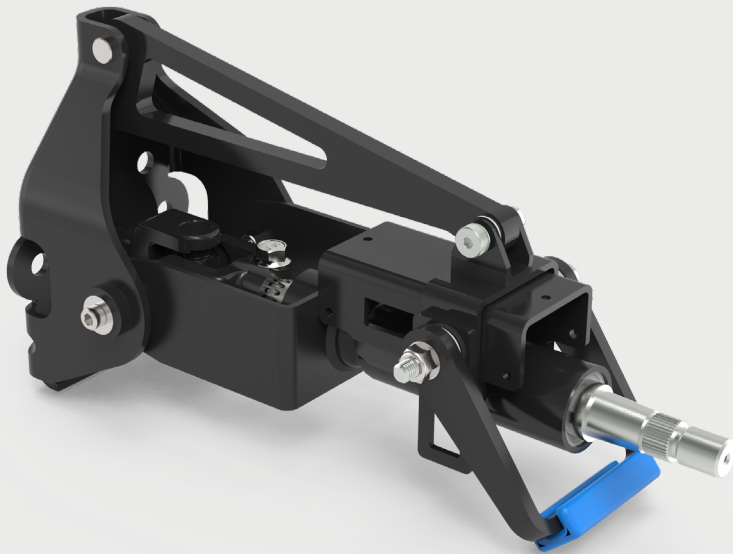

AT A GLANCE

- > A COMPACT STEERING COLUMN DESIGN SUITABLE FOR ANY OFF HIGHWAY VEHICLE APPLICATION WHERE SPACE IS A PREMIUM
- > SIMPLE, QUICK RELEASE FRICTION LOCK
- > TYPICAL TILT ANGLE RANGE: 16°
- > TYPICAL TELESCOPE STROKE: 38MM

PRODUCT DESCRIPTION

The CTT300 Compact Tilt and Telescope Steering Column has been designed specifically for Off Highway vehicle applications where space in the cabin is a premium.

Kongsberg Automotive offers a full range of fixed, tilt and telescopic steering columns, designed to withstand the most challenging environments for off-road vehicles. With our unique modular design, all columns provide best-in-class ergonomic working conditions for the driver.

Kongsberg Automotive offers completely tailored steering columns from our modular system according to customer specifications with full in-house design, development and validation services.



CTT300

COMPACT TILT AND TELESCOPE STEERING COLUMN



PRODUCT SPECIFICATIONS

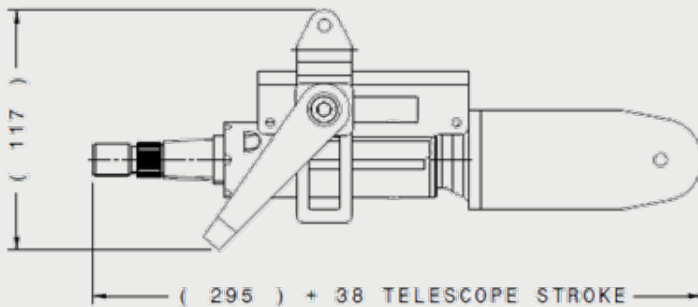
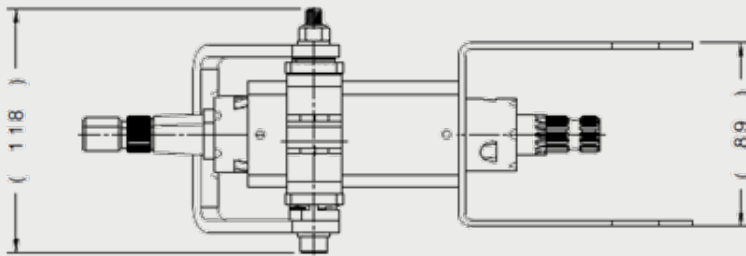
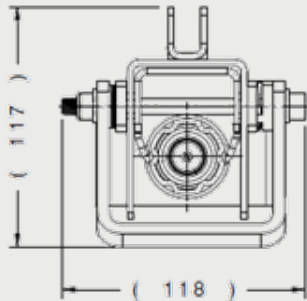

FEATURES

- > INFINITE ADJUSTMENT ON BOTH TELESCOPE AND TILT
- > COMPATIBLE WITH ALL TYPES OF HYDRAULIC PUMP INTERFACES
- > THE SPECIFICATION OF ALL STEERING COLUMNS IS ACCORDING TO ISO 5010
- > ALL COLUMNS MEETS KONGSBERG AUTOMOTIVE PRODUCT SPECIFICATION FOR OFF ROAD VEHICLES, AGRICULTURAL TRACTORS AND CONSTRUCTION EQUIPMENT

OPTIONS

- > LOCKING LEVER IS CUSTOMIZABLE
- > TELESCOPE RANGE CAN BE EASILY CUSTOMIZED
- > TILT ADJUSTMENT RANGE CAN BE EASILY CUSTOMIZED