

# CRC HAND CONTROL

COMPACT ROTARY ELECTRONIC HAND CONTROL



## AT A GLANCE

- > A COMPACT, LIGHTWEIGHT, ROTARY HAND CONTROL, SUITABLE FOR ANY OFF HIGHWAY VEHICLE APPLICATION
- > FRICTIONAL TORQUE CAN EASILY BE SET TO SUIT THE APPLICATION
- > AVAILABLE IN LEVER OR DIAL OPERATED VERSIONS
- > CAN BE CONFIGURED FOR ANALOGUE, PWM OR CANBUS SENSOR OUTPUTS
- > NON-CONTACT, HALL EFFECT SENSOR PROVIDES POSITION SENSING WITH ACCURACY AND RELIABILITY

## PRODUCT DESCRIPTION

The CRC – Compact Rotary Electronic Hand Control has been created as a smaller alternative to our successful EH3000 Hand Control. The CRC is intended for use as an engine idle speed control for any Off Highway vehicle with electronic fueling.

This device can be used as a stand alone product or it can be used in conjunction with Kongsberg Automotive Throttle pedal products to create a complete control system for virtually any type of heavy duty vehicle. It features the vSENSE™ non-contact sensor with patent-pending technology, configurable for a wide range of sensor output types.

The Kongsberg Automotive vSENSE™ non-contact, programmable Hall effect sensor seals out contaminants to provide enhanced reliability in all environments. With no moving parts to wear over time, the vSENSE™ sensor sets a new standard for accuracy and durability.





## PRODUCT SPECIFICATIONS

PARAMETERS	SPECIFICATIONS
RATED LIFE	> 500,000 CYCLES
OPERATING TEMPERATURE	-40°C TO +85°C
IP RATING	IP67

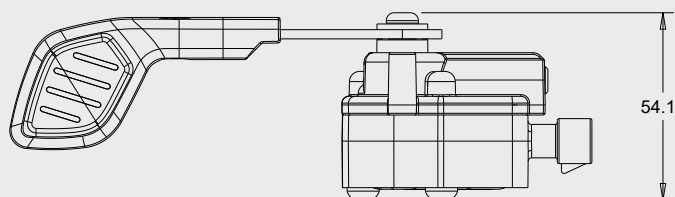
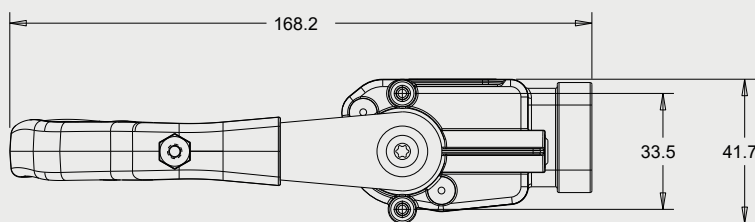
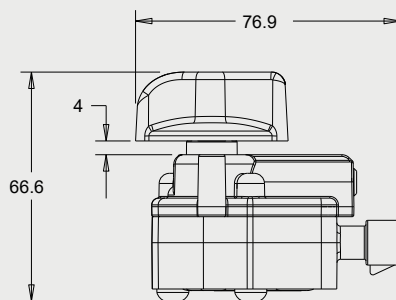
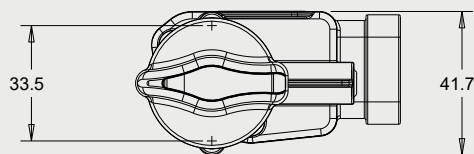

## FEATURES

- > 90° OF ROTATION
- > ADJUSTABLE ACTUATING FORCE
- > EASY, PANEL-MOUNT INSTALLATION
- > INTEGRATED SENSOR WITH METRIPACK 150 CONNECTOR

## OPTIONS

- > SENSOR OUTPUT CAN BE CONFIGURED FOR A MULTITUDE OF APPLICATIONS
- > STANDARD DIAL OR LEVER
- > OPTION TO FIT CUSTOM DIAL OR LEVER, IF REQUIRED